

Servo pillar CPSM



High load capability



High speed capability



Virtually maintenance free





Customized solutions

Up to 65% weight saving
Up to 100mm/s high speed
pillars

Servo pillar CPSM



Features

- High dynamic servo or brushless DC motor for high speed up to 100 mm/s
- High performance ball screw for high load capacity up to 5 kN
- Extruded aluminum profiles for a very robust design
- Manually adjusted gliders for very high stiffness and high eccentric loads
- Encoder system of the motor and high quality gearbox enable high positioning accuracy and high repeatability (0,1 mm)

Benefits

- High nominal power of the motor allows for high duty cycle of the pillar
- Customized motor adapter for highest flexibility (max. motor diameter 90 mm)
- Customized top and bottom plate to fit most of the applications
- Customized aluminum profile colour (anodized) to fit application design needs
- Optional brake to release the motor when it's in position and to increase the duty cycle
- Preloaded bearing arrangement also for ceiling mount applications (only available without damping system)

Product description

Telescopic pillars CPSM are the ideal solution to combine strong guiding functions with linear movements.

The robust, manually adjusted and virtually backlash-free aluminum extrusions are able to carry high excentric loads in push and pull directions.

To provide enough power to lift and lower heavy weights with high speed, the pillars are equipped with brushless DC or servo motors. Of course, Ewellix also supports the usage of preferred motors with a customizable motor interface.

Optional brakes and damping elements are key features that allow an effective usage in heavy duty industrial applications.

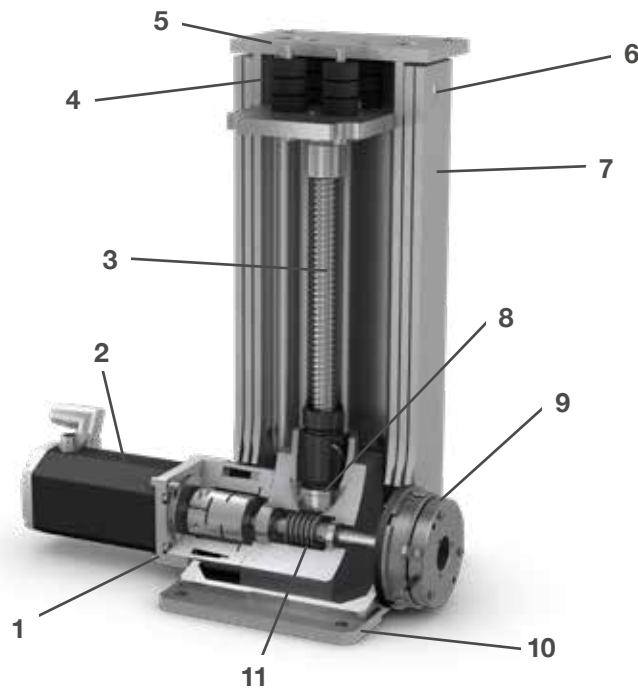

1. Standard or customized motor interface
2. Motor (Brushless DC or servo AC)
3. High efficiency ball screw
4. Optional damping system
5. Customized top plate
6. Backlash-free long lasting guiding pads
7. 2 or 3 section extruded aluminum guiding tubes
8. Preloaded bearing arrangement
9. Optional electromechanical brake
10. Customized bottom plate
11. Low friction worm gear reduction

CPSM

Servo pillar



Technical data

Designation	Symbol	Unit	w/o motor	BG75	1FK7034
Performance Data					
Continuous force @ zero speed	F_{c0}	kN	5	4,013	5
Continuous force @ max. speed	F_c	kN	5	4,013	4,013
Peak force @ zero speed	F_{p0}	kN	5	5	5
Peak force @ max. speed	F_p	kN	5	5	5
Dynamic load capacity	C	kN	21	21	21
Holding force (motorbrake option)	$F_{Hold-MB}$	kN	N/A	5	5
Holding force (external brake option)	$F_{Hold-EB}$	kN	5	5	5
Max. linear speed	v_{max}	mm/s	–	62	100
Max. acceleration	a_{max}	m/s ²	6	6	6
Duty cycle	D	%	100	100	100
Mechanical Data					
Screw type	–	–	Ball screw	Ball screw	Ball screw
Screw diameter	d_{screw}	mm	20	20	20
Screw lead	p_{screw}	mm	10	10	10
Lead accuracy	–	–	G7	G7	G7
Stroke ¹⁾	s	mm	100...700	100...700	100...700
Internal overstroke each side	s_0	mm	1	1	1
Backlash	$s_{backlash}$	mm	0,07	0,07	0,07
Gear reduction	i	–	10	10	10
Efficiency	η	%	58	52	51
Electrical Data					
Motor type	–	–	N/A	Brushless DC	Servo
Nominal voltage	U	V DC	N/A	40	N/A
Nominal current	I	A	N/A	12,7	1,3
Peak current	I_{peak}	A	N/A	10,8	1,9
Nominal power	P	kW	N/A	0,45	0,6
Environment					
Ambient temperature	$T_{ambient}$	°C	0...+50	0...+50	0...+50
Max. humidity	ϕ	%	95	95	95

¹⁾ By 100 mm steps

Ordering key

See page 9

Dimensional drawing

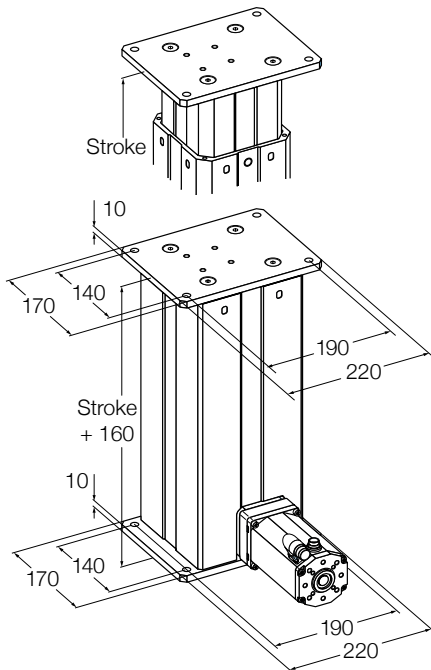

Performance diagram

Pillar output speed [mm/s]

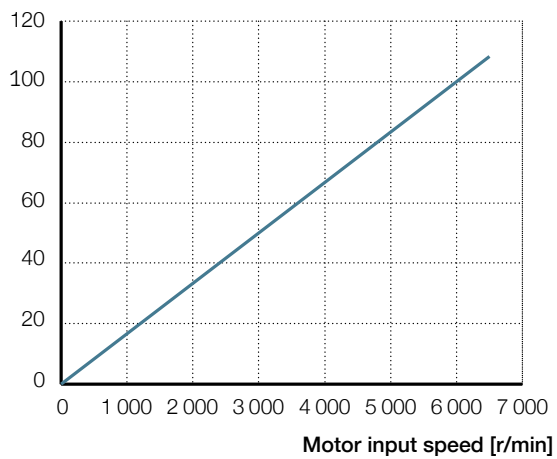

Performance diagrams

Load [N]

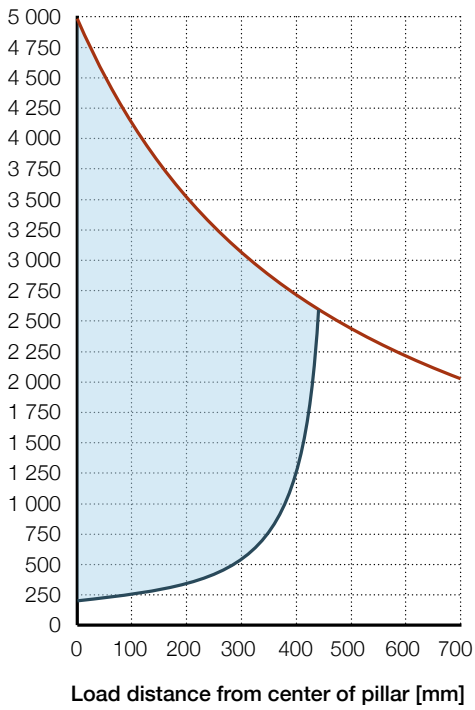

Load [N]

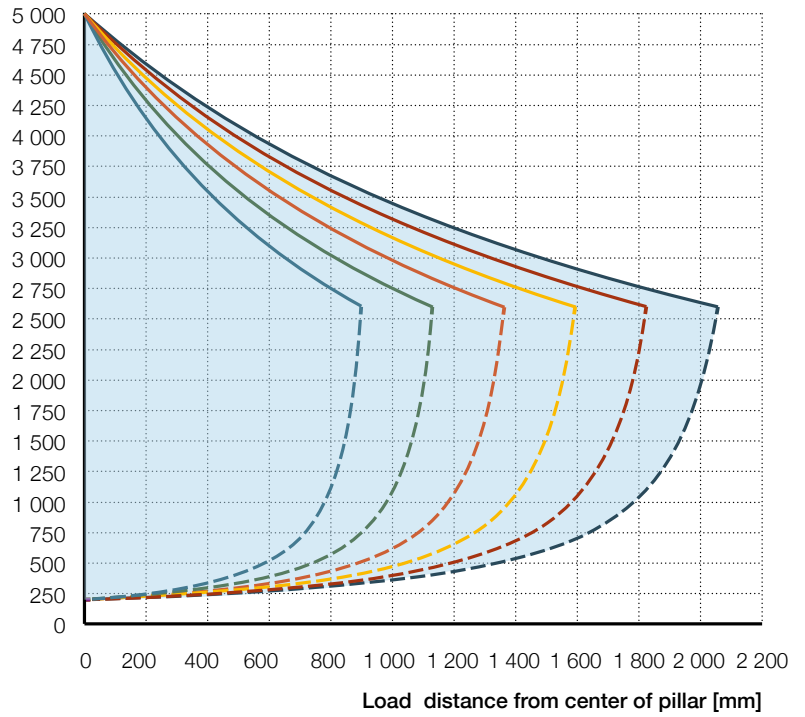

- | | | |
|---------------------------------|---------------------------------|---------------------------------|
| — Over load limit stroke 200 | — Over load limit stroke 400 | — Over load limit stroke 600 |
| - - Under load limit stroke 200 | - - Under load limit stroke 400 | - - Under load limit stroke 600 |
| — Over load limit stroke 300 | — Over load limit stroke 500 | — Over load limit stroke 700 |
| - - Under load limit stroke 300 | - - Under load limit stroke 500 | - - Under load limit stroke 700 |

Adapter for third-party motors

In order to attach your preferred motor to the pillar, Ewellix offers tailormadesolutions within the specifications below. For motor speciications which are not covered by those below, please contact Ewellix.

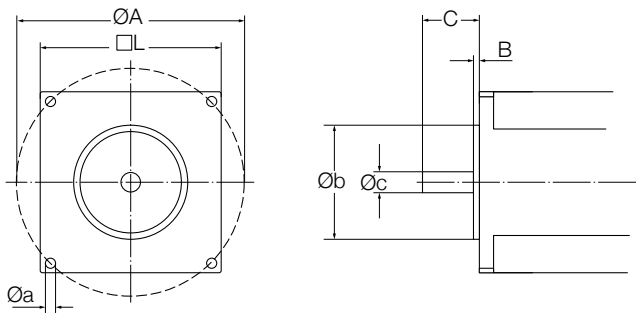

Designation	Symbol	Unit	Min.	Max.
Motor housing	□ L	mm	60	95
Motor centering	$\varnothing b$	mm	47	95
Centering height	B	mm	1	5
Fixing diameter	$\varnothing A$	mm	52	103
Shaft diameter	$\varnothing c$	mm	11	19
Shaft lenght	C	mm	15	48

Ordering key

Linear units

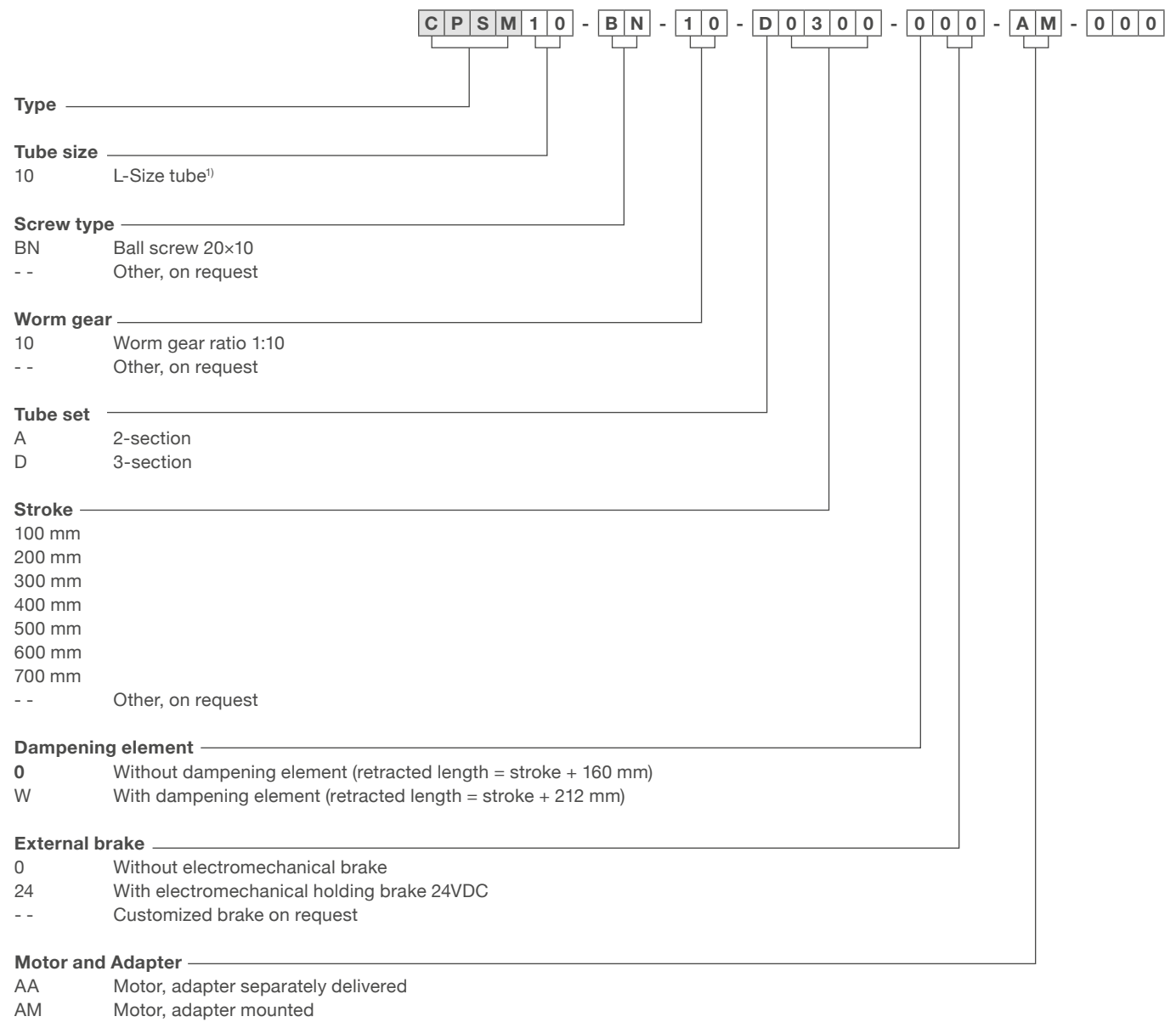

¹⁾3- sections: □ 163 mm / 2-sections: □ 146 m



ewellix.com

© Ewellix

All contents of this publication are the property of Ewellix, and may not be reproduced or given to third parties (even extracts) without permission. Although great care has been taken in the production of this catalog, Ewellix does not take any responsibility for damage or other loss resulting from omissions or typographical errors. The photo may differ slightly in appearance from the actual product. Due to continuous improvements being made in our products, the product's appearance and specifications are subject to change without notice.

PUB IL-07018/1-EN-May 2020